

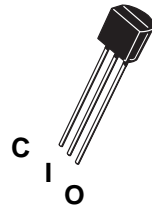

79L05 (n.d)

Negative-Voltage Regulators

- 3-Terminal Regulators
- Output Current Up to 100 mA
- No External Components Required
- Internal Thermal-Overload Protection
- Internal Short-Circuit Current Limiting
- Provided Pb-Free packages from the end of 2004



TO-92
79L05ACZ



description

79L05 (n.d) is fixed negative-voltage integrated-circuit voltage regulators is designed for a wide range of applications. These include on-card regulation for elimination of noise and distribution problems associated with single-point regulation. In addition, they can be used to control series pass elements to make high-current voltage-regulator circuits. One of these regulators can deliver up to 100 mA of output current. The internal current-limiting and thermal-shutdown features make them essentially immune to overload. When used as a replacement for a zener-diode and resistor combination, these devices can provide effective improvement in output impedance of two orders of magnitude, with lower bias current.

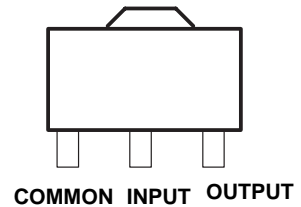

SOT-89
79L05CPK

equivalent schematic

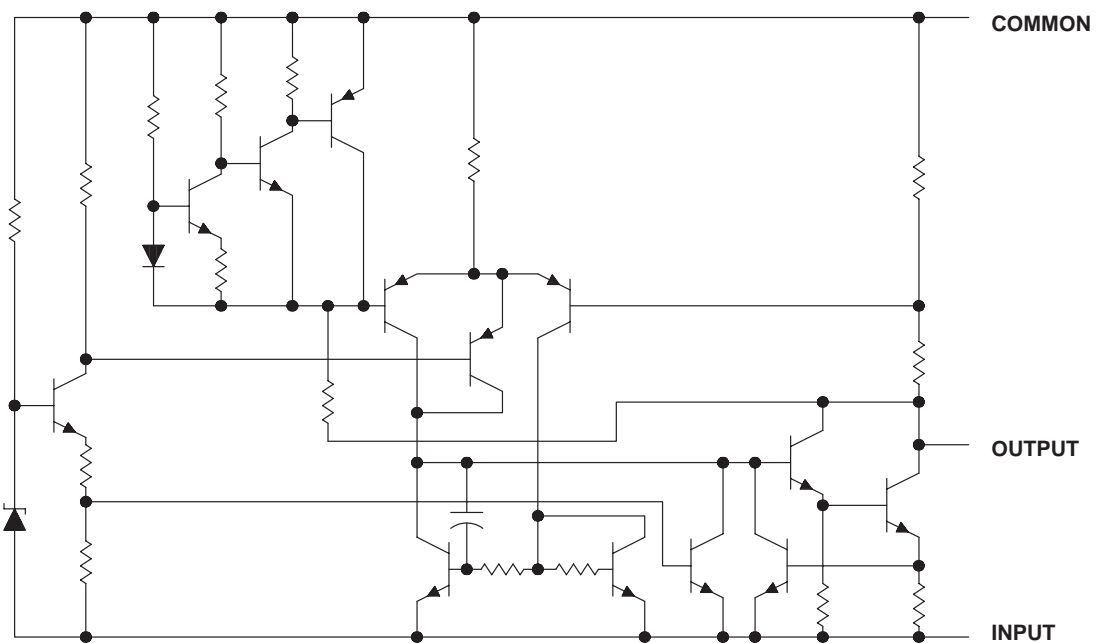



79L05 (n.d)

Negative-Voltage Regulators

Absolute maximum ratings over operating temperature range (unless otherwise noted) (TO-92)

ITEM	MAX RATINGS	UNIT
Input voltage	-30	V
Operating free-air, case, or virtual junctions temperature range	0 to 150	°C
Storage temperature range	-65 to 150	
Lead temperature 1.6 mm (1/16 inch) from case for 10 seconds	260	

Recommended operating conditions

PARAMETER	MIN	MAX	UNIT
Input voltage V_i	-7	-20	V
Output current, I_o		40	mA
Operating virtual junction temperature, T_J	0	70	°C

Electrical characteristics at specified virtual junction temperature, $V_i = 10V$, $I_o = 40mA$ (TO-92)

PARAMETER	TEST CONDITIONS*	79L05nd			UNIT	
		MIN	TYP	MAX		
Output voltage**	25°C	-4.8	-5	-5.2	V	
	$I_o = 1mA$ to 40mA, $V_i = -7V$ to -20V $I_o = 1mA$ to 70mA	0°C to 125°C	-4.75	-5		-5.25
			-4.75	-5		-5.25
Input regulation	$V_i = -7V$ to -20V	25°C		15	150	mV
	$V_i = -8V$ to -20V			12	100	
Ripple rejection	$V_i = -8V$ to -18V, $f = 120Hz$	25°C	41	49	dB	
Output regulation	$I_o = 1mA$ to 100mA	25°C		20	60	mV
	$I_o = 1mA$ to 40mA			10	30	
Output noise voltage	$f = 10 Hz$ to 100 KHz	25°C		40	µV	
Dropout voltage	$I_o = 100mA$	25°C		1.7	V	
Bias current		25°C			6	mA
		125°C			5.5	
Bias current change	$V_i = -8V$ to -20V	0°C to 125°C			1.5	
	$I_o = 1mA$ to 40mA				0.1	

* Pulse testing techniques are used to maintain the junction temperature as close to the ambient temperature as possible. Thermal effects must be taken into account separately. All characteristics are measured with a 0.33µF capacitor across the input and a 0.1 µF capacitor across the output.

** This specification applies only for dc power dissipation permitted by absolute maximum ratings.



79L05 (n.d)

Negative-Voltage Regulators

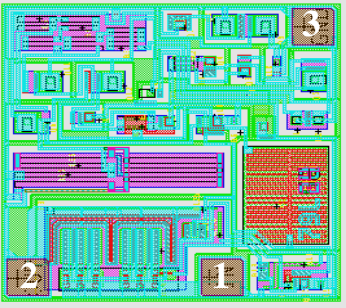
<p>CHIP APPEARANCE</p> 	CHIP SIZE		0,85 × 0,85 mm	
	CHIP THICKNESS		460 ± 20µm (or 280 ± 20µm)	
	BONDING PAD DIMENSION	1	INPUT	92 × 92 µm
		2	OUTPUT	92 × 92 µm
		3	GROUND	92 × 92 µm
	SCRIBE LINE WIDTH		80 µm	
	TOP METAL		Al	
	BACK METAL		– (or Ti-Ni-Ag)	
WAFER SIZE		100 mm		

Chip name:79Lxx n.d